

Security Systems



PENTAX IMAGING SYSTEMS - SECURITY SYSTEMS



55X ZOOM LENS WITH PENTAX ATMOSPHERIC INTERFERENCE REDUCTION

- Focal Length 12 - 1,680mm
- Reduction of Heat Haze
- Integrated Electronic Image Stabilizer
- Reduction of Airborne Interference, e. g. Fog, Rain, Sand, Smoke, Snow
- Autofocus
- RS232C Interface



PAIR
Pentax Atmospheric Interference Reduction

PENTAX

H55ZAME-F-PR01

PAIR
Pentax Atmospheric Interference Reduction

The new **PAIR-Technology** reduces the affect of particles in the air, such as fog, rain, sand, smoke and snow.

The provided software allows remote control of lens functions, including zoom, focus, iris and operation of the internal 2.5x Extender.

In addition, the software includes reliable autofocus with the click of a mouse - a very useful advantage in super-telephoto position, when depth of field is extremely low.

The lens is equipped with a standard RS232 interface and comes with open platform control software and is compatible with standard CCTV colour cameras.

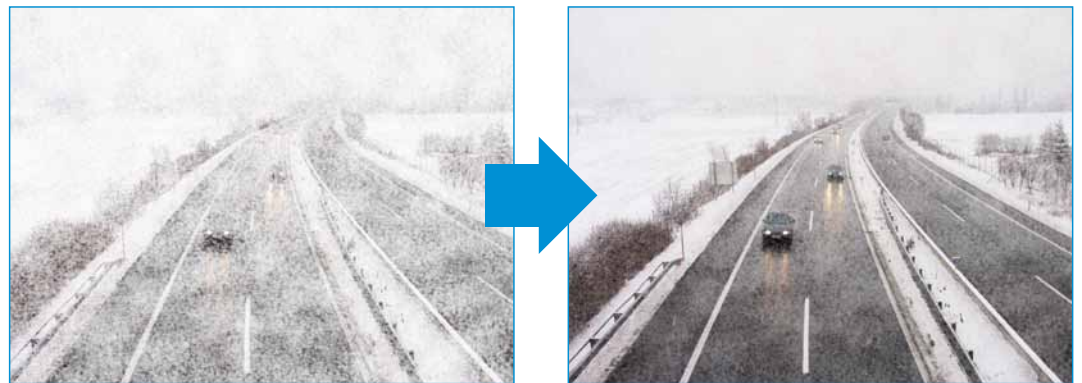

Also available with transport case TK-01

All PENTAX 55x zoom lenses are equipped with fast motors. This is especially important when monitoring moving objects.

The main usage of these lenses is in the area of "Homeland Security", including surveillance of:

- Sea and Airports
- Borders
- Sports Stadiums
- City Centers and Squares
- Coastlines

H55ZAME-F-PR02

PAIR
Pentax Atmospheric Interference Reduction

The new **PAIR II-Technology** includes all the features of H55ZAME-F-PR01, with the addition of further integrated functions, to enhance image quality.

The system is able to reduce heat haze, which appears not only on hot sunny days, but also cold clear days or by the hot exhaust gases emitted by aircraft etc.

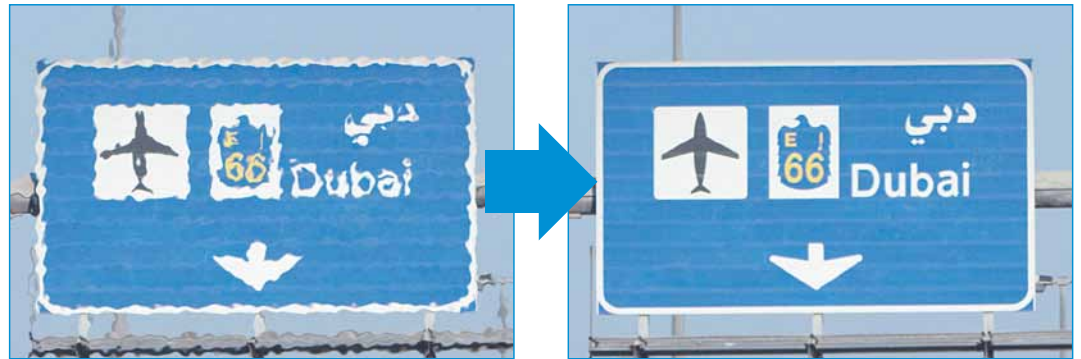

The lens has an integrated electronic image stabilizer, which is particularly useful at telephoto, when even small movements of the lens or pan/tilt head or the effects of wind buffeted the mast will cause blur. The image stabilizer corrects the blur in "real time" allowing monitoring even when other systems cannot provide useful images any more.

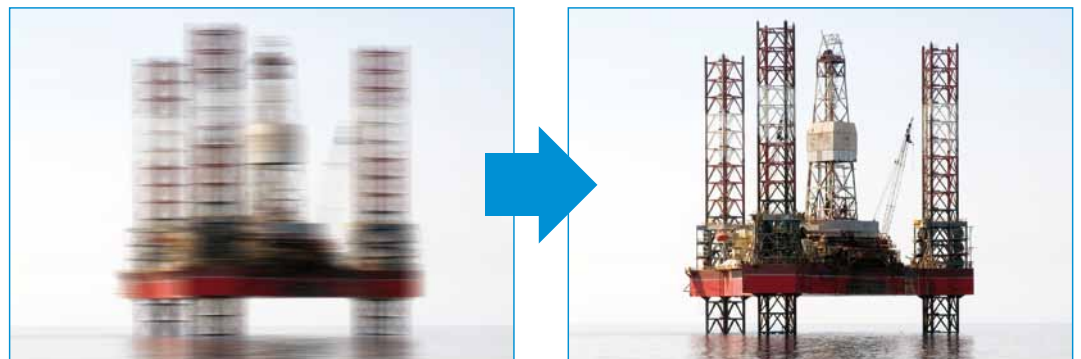

PAIR-II also offers Backlight Compensation and Night Image Enhancement as "add ons" to the compensation functions of the camera.

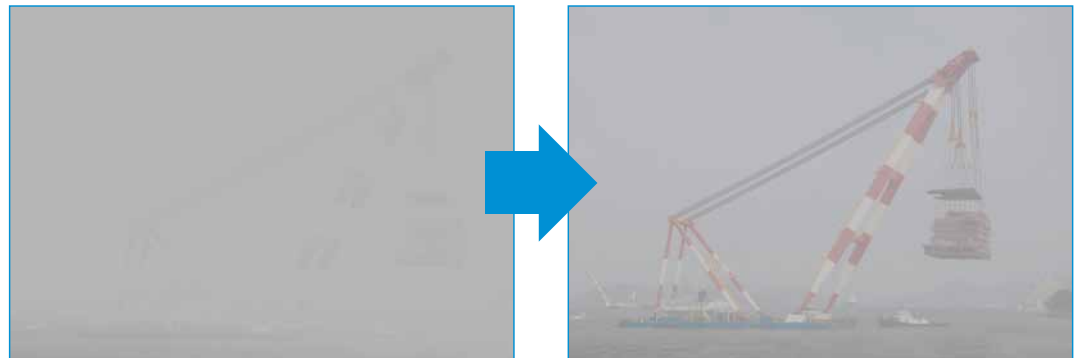

All functions are incorporated into the lens making installation and system integration as simply and cost effective as possible.

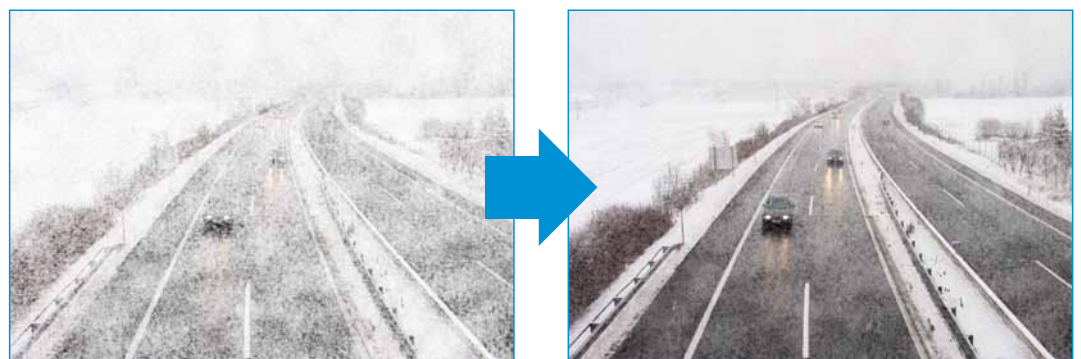

Technical Data / Specifications

System	H55ZAME-F-PR01	H55ZAME-F-PR01 with 2,5X-Extender	H55ZAME-F-PR02	H55ZAME-F-PR02 with 2,5X-Extender
Format	1/2" (6.4 x 4.8 mm)	1/2" (6.4 x 4.8 mm)	1/2" (6.4 x 4.8 mm)	1/2" (6.4 x 4.8 mm)
Focal Length	12.00 - 660 mm	30.5 - 1,680 mm	12.00 - 660 mm	30.5 - 1,680 mm
Iris	F 4 - F 360	F 10 - F 900	F 4 - F 360	F 10 - F 900
Mount	C	C	C	C
Horizontal Angle of View	31.65° - 0.56°	12.06° - 0.22°	31.65° - 0.56°	12.06° - 0.22°
Min. Object Distance	7 m	7 m	7 m	7 m
Filter Thread	105 mm	105 mm	105 mm	105 mm
Iris Control Video	VS (Videosignal)	VS (Videosignal)	VS (Videosignal)	VS (Videosignal)
Dimensions	355 (L) x 155 (W) x 137 (H) mm	355 (L) x 155 (W) x 137 (H) mm	355 (L) x 155 (W) x 137 (H) mm	355 (L) x 155 (W) x 137 (H) mm
Weight	5,780 g	5,780 g	5,780 g	5,780 g
Specials	Reduction of Atmospheric Interferences caused by Particles in the Air, Autofocus with the Click of a Mouse, RS232C Interface		Functions of H55ZAME-F-PR01 + Heat Haze Reduction + Integrated Electronic Image Stabilizer	

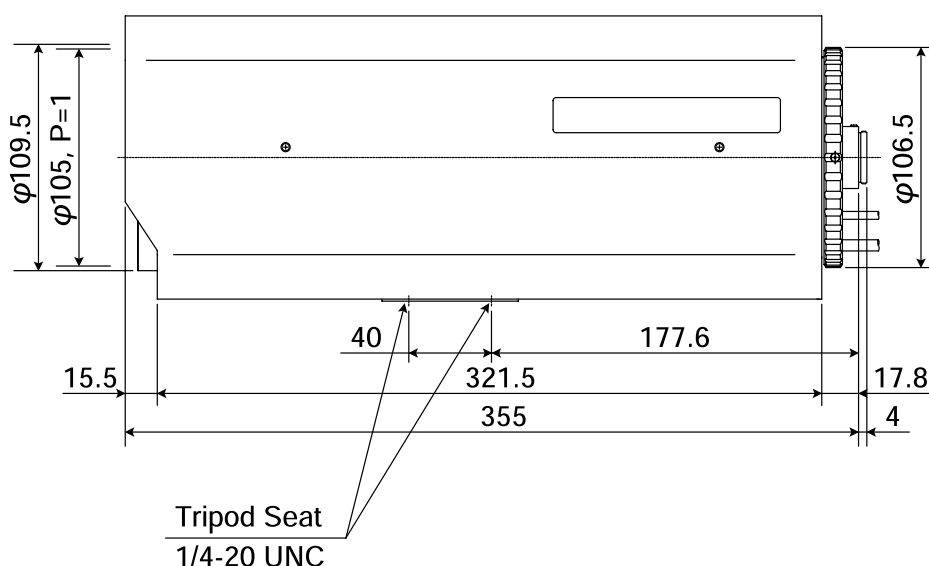
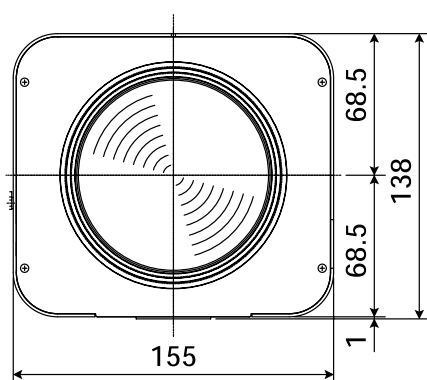

GERMANY, AUSTRIA, SWITZERLAND, EUROPE, MIDDLE EAST, AFRICA

PENTAX Imaging Systems GmbH
Security Systems
Julius-Vosseler-Str. 104
22527 Hamburg
Germany
Phone: +49-(0)40-5 61 92-109
Fax: +49-(0)40-5 61 92-334
security@pentax.de
www.pentax.de

UNITED KINGDOM, IRELAND

PENTAX Imaging Systems Ltd.
Security Systems
Heron Drive
Langley
Slough SL3 8PN
England
Phone: +44-(0)1753-21 10 92
Fax: +44-(0)1753-21 10 90
cctv.sales@pentax.co.uk
www.pentax.co.uk

FRANCE

PENTAX Europe Imaging
Systems SAS
Security Systems
112 Quai de Bezons, B.P. 204
95106 Argenteuil Cedex
France
Phone: +33-(0)1-30 25 75 75
Fax: +33-(0)1-30 25 74 47
security@pentax.fr
www.pentax.fr

BELGIUM, NETHERLANDS, LUXEMBURG

PENTAX Imaging Systems GmbH
Security Systems
Julius-Vosseler-Str. 104
22527 Hamburg
Germany
Phone: +32-(0)2-3 06 11 97
Fax: +32-(0)2-3 06 12 97
cctv-info@pentaxeuropa.com
www.pentax.nl
www.pentax.be

PENTAX